



INSTALLATION INSTRUCTIONS FOR DOUBLE AND TRIPLE STATION SENSOR ACTIVATED SOLID SURFACE LAVATORY SYSTEMS

EW-72000
Double Station
Sensor Activated
Solid Surface Lavatory System



EW-72000-xx-SD Model Shown

EW-73000
Triple Station
Sensor Activated
Solid Surface Lavatory System



EW-73000-xx-SD Model Shown

LIMITED WARRANTY

Sloan Valve Company warrants its Optima EW-70000 Series Lavatory Systems to be made of first class materials, free from defects of material or workmanship under normal use and to perform the service for which they are intended in a thoroughly reliable and efficient manner when properly installed and serviced, for a period of three years (1 year for special finishes) from date of purchase. During this period, Sloan Valve Company will, at its option, repair or replace any part or parts which prove to be thus defective if returned to Sloan Valve Company, at customer's cost, and this shall be the sole remedy available under this warranty. No claims will be allowed for labor, transportation or other incidental costs. This warranty extends only to persons or organizations who purchase Sloan Valve Company's products directly from Sloan Valve Company for purpose of resale.

THERE ARE NO WARRANTIES WHICH EXTEND BEYOND THE DESCRIPTION ON THE FACE HEREOF. IN NO EVENT IS SLOAN VALVE COMPANY RESPONSIBLE FOR ANY CONSEQUENTIAL DAMAGES OF ANY MEASURE WHATSOEVER.

LAVATORY SYSTEM ROUGH-IN

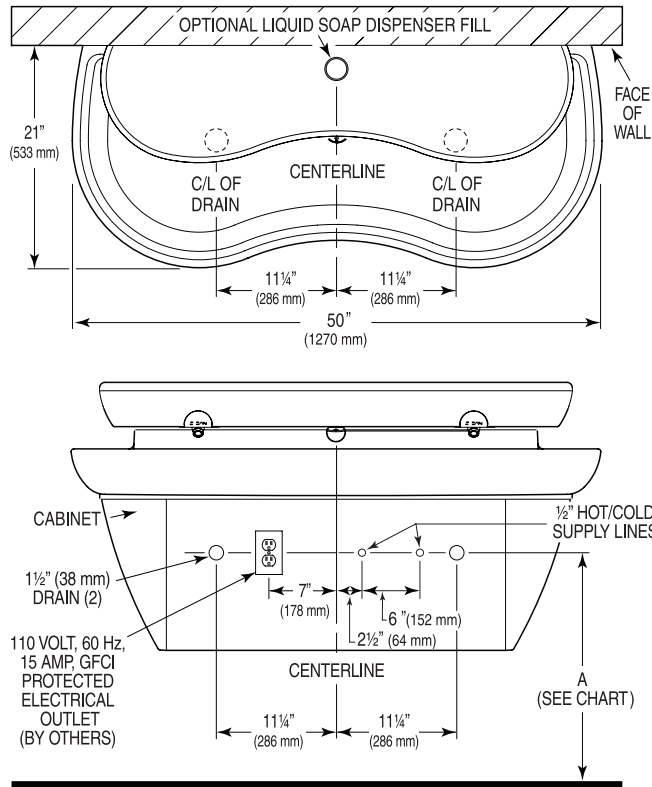

MODEL EW-72000
Double Station Lavatory System
 Flow Rate: 0.5 gpm/1.9 Lpm Max. Spray
 Lavatory System Weight (Packaged):
 Approximately 145 Lbs/65 Kg

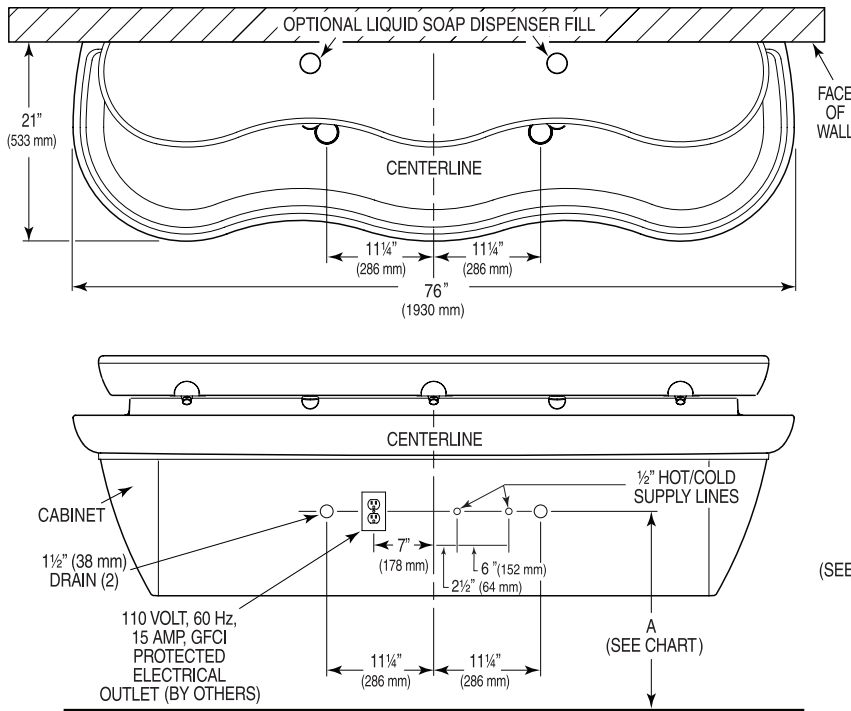
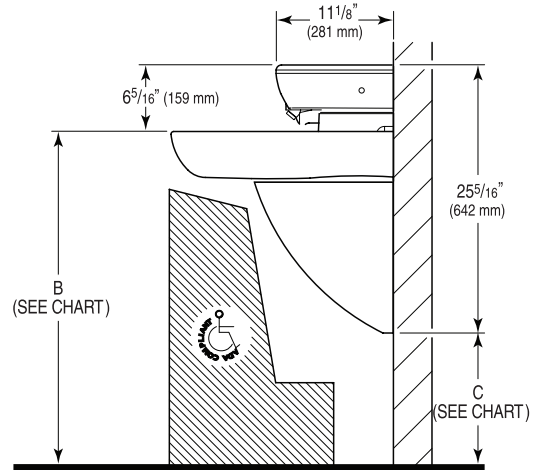

MODEL EW-73000
Triple Station Lavatory System
 Flow Rate: 0.5 gpm/1.9 Lpm Max. Spray
 Lavatory System Weight (Packaged):
 Approximately 170 Lbs/80 Kg

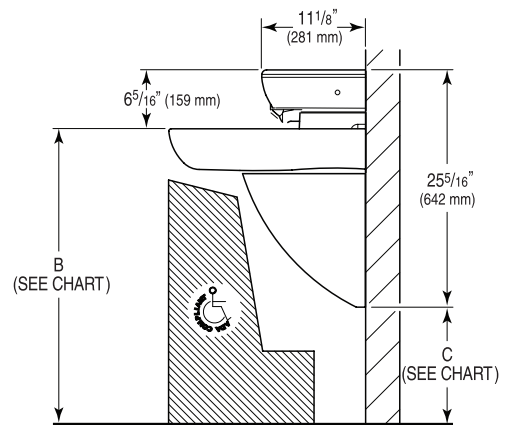

VARIABLE MOUNTING HEIGHT CHART					
♿	DIMENSION DESCRIPTION	T.A.S. † AGES 4-10	T.A.S. † AGES 11-15	A.D.A. STANDARD	
	A	ROUGH-IN	20-1/2" (521 mm)	22-1/2" (572 mm)	24" (610 mm)
	B	RECOMMENDED RIM HEIGHT	29-7/8" (759 mm)	31-7/8" (810 mm)	33" (838 mm)
	C	FLOOR CLEARANCE	10-7/8" (276 mm)	12-7/8" (327 mm)	14" (356 mm)
	D	NOMINAL FRAME HEIGHT ‡	25-1/8" (638 mm)	27-1/8" (689 mm)	28-1/4" (718 mm)

Consult Federal and all applicable state and local codes for all accessories not supplied by SLOAN for compliance to accessibility requirements.

‡ Refer to Step 3.

PRIOR TO INSTALLATION

Prior to installing the Sloan Optima EW-70000 Series Lavatory System, install the items listed below. Also, refer to the appropriate rough-in diagram on Page 2.

- Install electrical receptacle(s) for plug-in transformer(s) — 120 VAC, 2 amp service for each ETF-233 (24 VAC, 35 VA) plug-in transformer used.
- Hot and cold water supply lines or tempered water supply line (if there is no tempered water supply, install thermostatic mixing valve between hot and cold water supply)
- Drain lines

Important:

- ADEQUATE STRUCTURAL SUPPORT IN OR BEHIND THE WALL IS REQUIRED. REFER TO THE APPROPRIATE ROUGH-IN DIAGRAM ON PAGE 2 FOR DRY WEIGHT OF SINK. **STRUCTURAL SUPPORT MUST HAVE A MINIMUM PULLOUT RATING OF 1000 POUNDS (450 Kg) FOR EACH FASTENER.**
- ALL ELECTRICAL WIRING SHOULD BE INSTALLED IN ACCORDANCE WITH NATIONAL/LOCAL CODES AND REGULATIONS.
- ALL PLUMBING SHOULD BE INSTALLED IN ACCORDANCE WITH APPLICABLE CODES AND REGULATIONS.
- A 24 VAC STEP-DOWN TRANSFORMER MUST BE USED FOR HARDWARE APPLICATIONS.
- USE APPROPRIATE PRECAUTIONS WHILE CONNECTING TRANSFORMER TO 120 VAC POWER SOURCE.

- DO NOT PLUG TRANSFORMER INTO POWER SOURCE (RECEPTACLE) UNTIL ALL WIRING IS COMPLETED. PERMANENT DAMAGE TO THE TRANSFORMER AND CIRCUIT CONTROL MODULE WILL RESULT IF 24 VAC WIRES TOUCH EACH OTHER OR SHORT WHEN POWER SUPPLY IS ACTIVE.
- BEFORE CONNECTING FLEX HOSES TO SUPPLY STOPS, FLUSH ALL WATER LINES UNTIL WATER IS CLEAR.

TOOLS REQUIRED FOR INSTALLATION

- Electric drill for drilling anchor holes.
- Standard sockets and open end wrench set for installing anchoring fasteners and connecting water lines.
- Pipe wrench for installing drain lines.
- Phillips and straight blade screwdrivers.

SINK LOCATION

Determine the appropriate wall location for the Lavatory System. Consider that hot and cold water supply lines, drain lines, and an electrical source (receptacle or wiring depending on type of transformer used) will be required. Compare the physical dimensions of the Lavatory System to the space available for the installation. If wall is not load bearing, a carrier may be required behind the wall. Refer to the appropriate Rough-in diagram on Page 2 for Lavatory System dimensions.

Prior to Lavatory System installation, electric wiring, water supply and drain must be installed.

1 Install Thermostatic Mixing Valve

- A** If there is no tempered water supply, install Thermostatic Mixing Valve between hot and cold water supply.

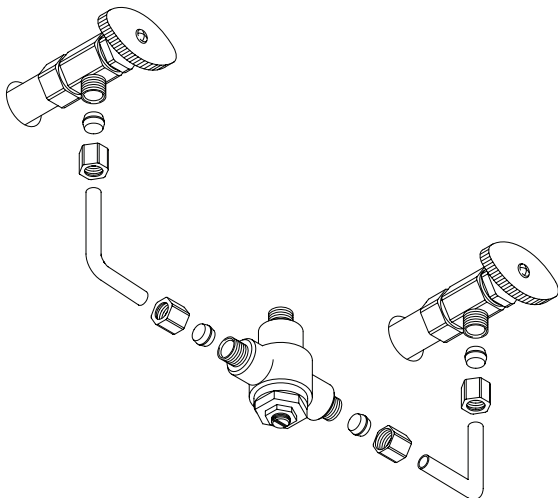

2 Remove End Caps from Frame

- A** Loosen (do not remove) screws on inside of frame.

- B** Remove both End Caps by removing the two outer screws on each Cap. Slide Cap forward in slot and pull it out through enlarged hole in Frame.

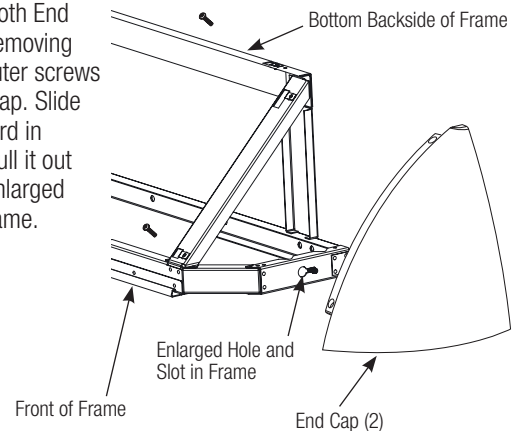

- C** For triple station sinks, remove the Front Panel Support.

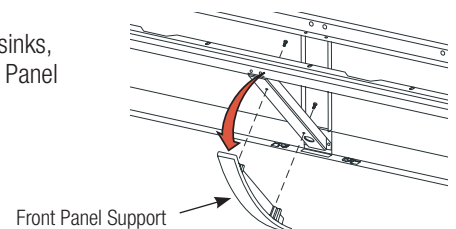

3 Mount Frame to Wall

A If desired, apply adhesive to back surfaces of Frame.

B Mount Frame to wall using 3/8" fasteners with **1000 lb min pull out strength** in the following locations:

1. Each hole in the extreme outer corners of top support
2. One of either of the two holes in the top position of each upright
3. The lower hole location in each upright

Fasteners may be optionally applied to any of the remaining mounting hole locations. Level Frame in both directions before tightening fasteners securely.

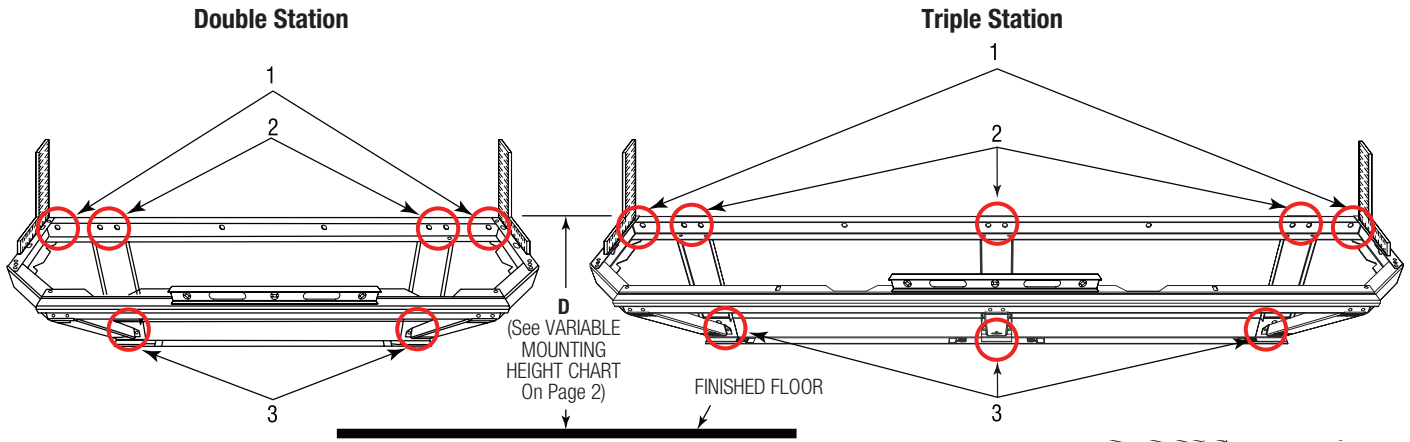

C For triple station sinks, reinstall the Front Panel Support.

4 Mount Basin to Frame

Note: If desired, Grid Strainers may be installed prior to mounting Basin to the Frame. Refer to Step 5.

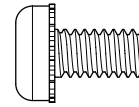

1/4"-20 x 1/2" Pan Head Screw (SEMS)
(Actual Size)

A Mount Basin to Frame using 1/4"-20 x 1/2" SEMS fasteners.

B If desired, apply caulk between Basin and wall.

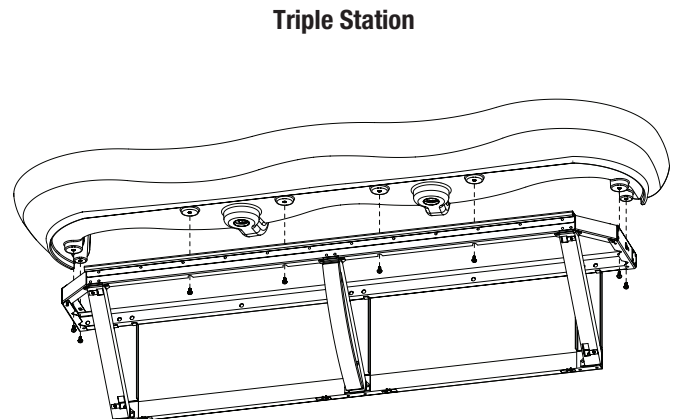
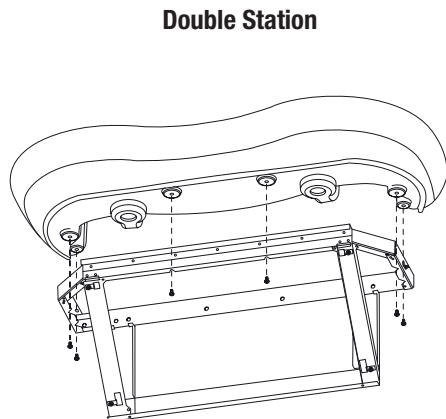

5 Install Grid Strainers and Connect Drain Line

A Install Grid Strainers.

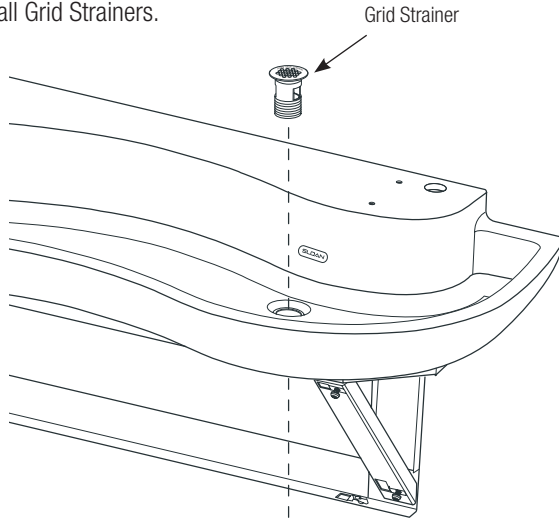

B Plumb drain outlets to wall.

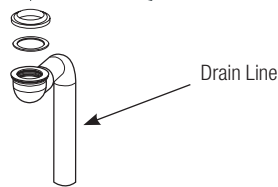

6 Remove Cover from Head

A Insert T-Handled Wrench into access holes on left and right sides of the Head. Turn top of wrench toward front of Head rotating until it stops to fully open the latch. Remove the Cover.

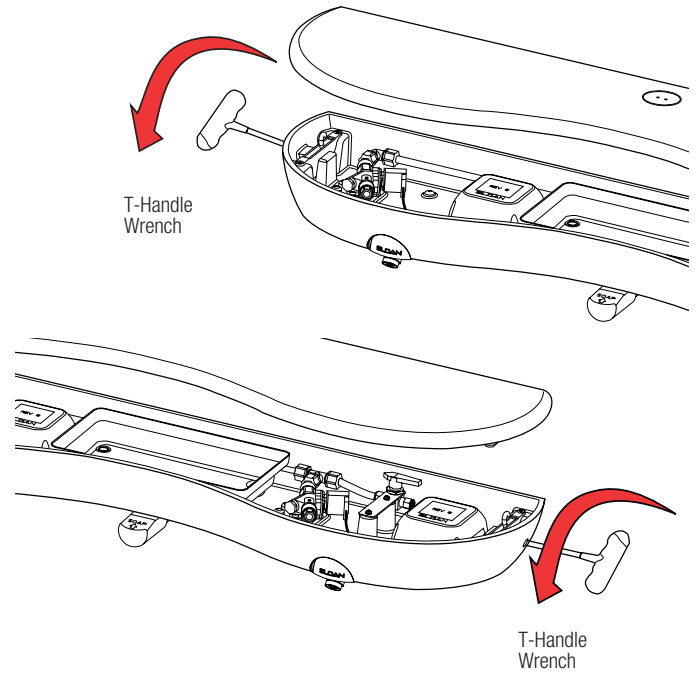

7 Mount Head to Basin

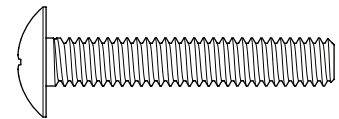

1/4"-20 x 1-1/2" Truss Head Screw
(Actual Size)

A If desired, apply caulk between Basin and Head.

Double Station

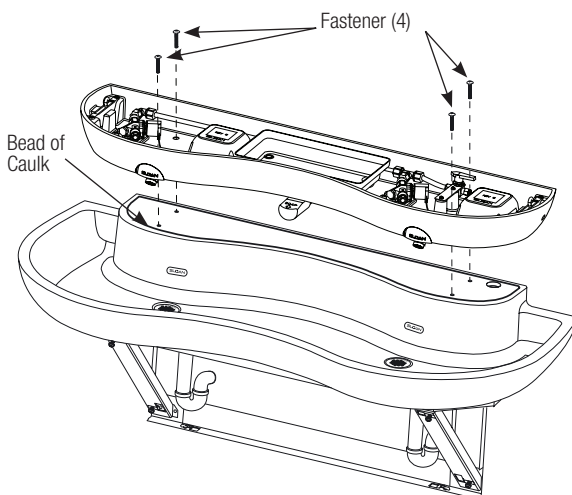

B Mount Head to Basin using 1/4"-20 x 1-1/2" Truss Head Screws.

Triple Station

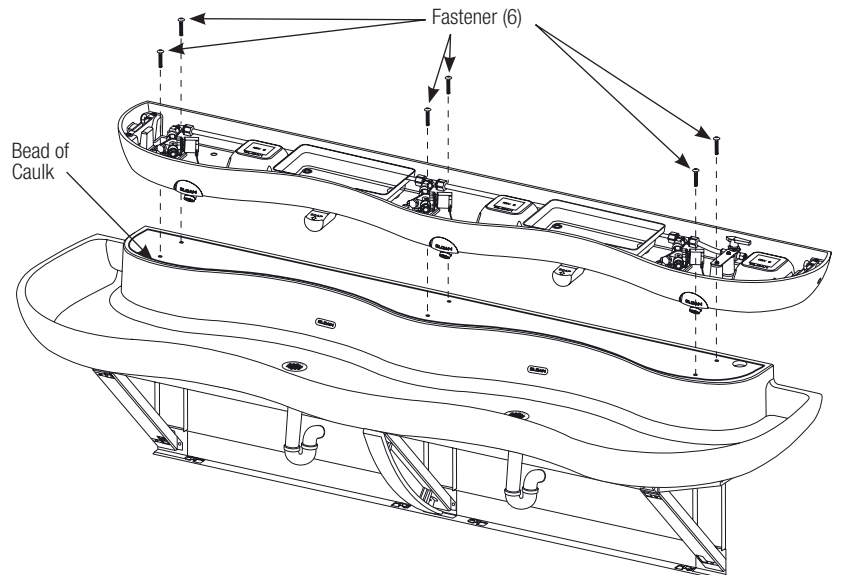

8 Connect Supply Line to Shut Off Valve in Head

- A** Drop Power Cord through service access hole.
- B** Drop Braided Hose Supply Line through service access hole.
- C** Connect Braided Hose Supply Line to right side of Shut Off Valve in Head.

Note: To ease Supply Line installation, remove the two screws holding the Shut Off Valve Bracket. After connecting Supply Line, reinstall the Shut Off Valve Bracket.

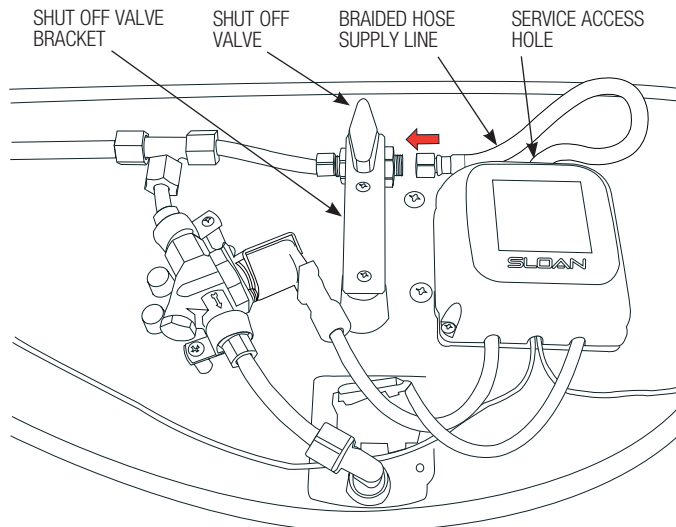

9 Connect Supply Line to Thermostatic Mixing Valve

- A** Install water line.

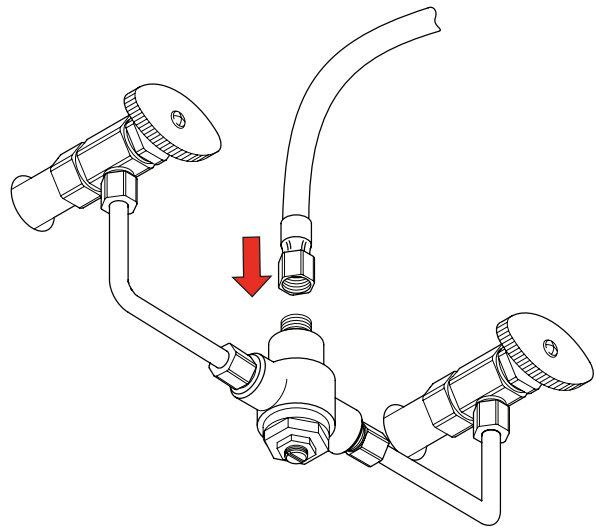

10 Connect Power Cable to Transformer and Plug Transformer into Receptacle

- A** Connect Spade Terminals on Power Cord to the Transformer.

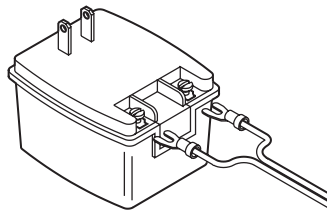

- B** Plug Transformer into outlet.

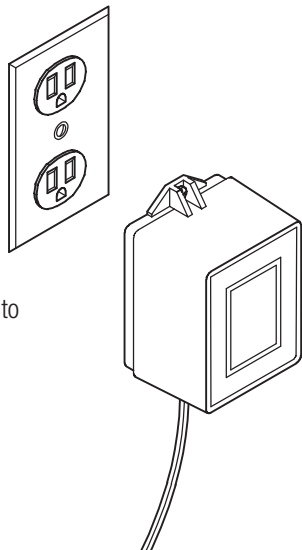

11 Open Shut Off Valve, Turn on Water Supply, Check for Water Leaks and Install End Caps

- A** Open Shut Off Valve and turn on water supply.
- B** Check all plumbing for water leaks.

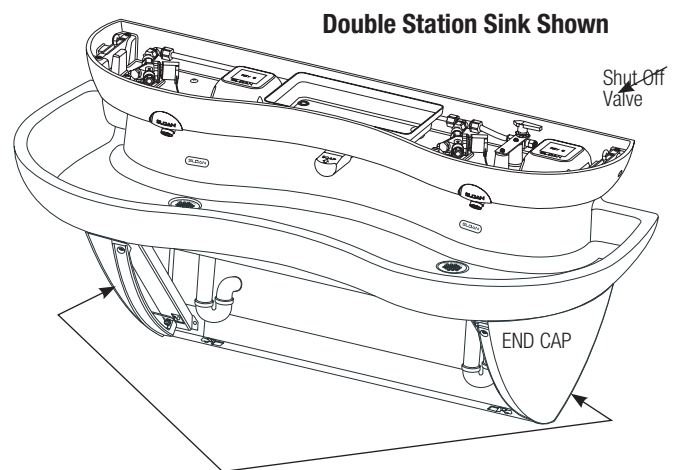

- C** Replace End Caps. Insert the screw located on the inside of the Cap into the enlarged hole of the Frame. Then slide the Cap into place. Loosely install the two front screws. Slide End Cap UP to eliminate any gap between the End Cap and Basin. Tighten the inside screw securely. Lastly, tighten the two front screws securely. Follow the same procedure for the second End Cap.

12 Install Cover and Front Panel(s)

A Replace Cover and latch firmly in place with T-Handled Wrench (Rotate top of handle toward wall until latch snaps into position).

B Replace Front Panel(s) by hanging top lip of Panel into track of Trim Rail under Basin. Swing panel into position and affix with 2 Fasteners. Triple Station Models — repeat this procedure for second panel.

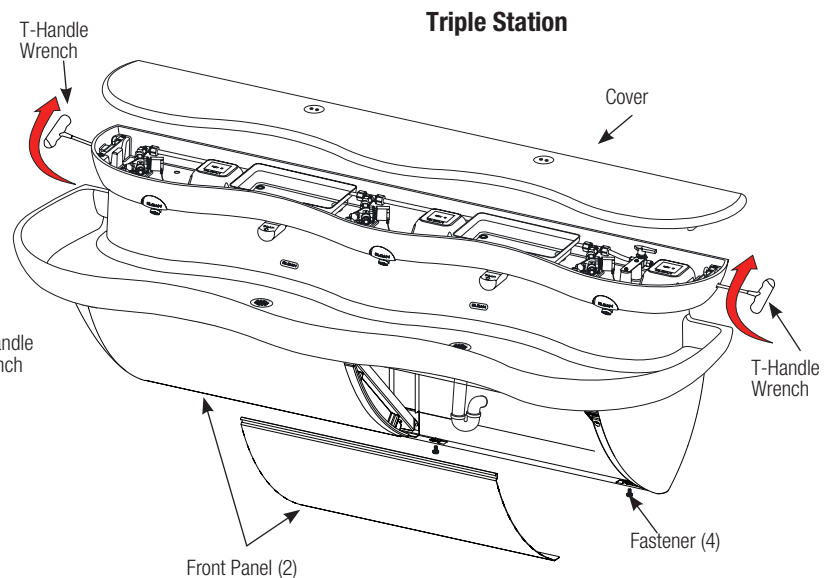
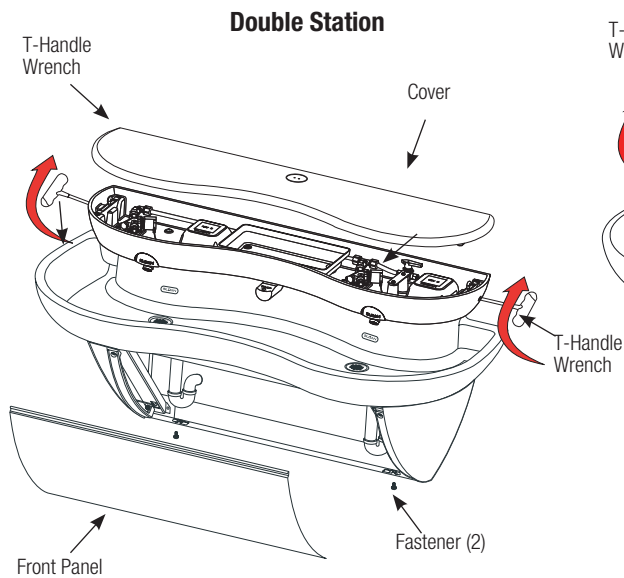

Solenoid Screen Filter Cleaning

- A** Before cleaning the Screen Filter, turn off the water supply at supply stop(s).
- B** Activate the Spray Head to relieve any pressure in the system.
- C** Remove Cover as instructed in Step 6.
- D** Unscrew the Filter Cap and remove it from the Solenoid Valve Housing.
- E** Carefully remove the Screen Filter from the Solenoid Valve Housing.
- F** Clean the Screen Filter using fresh tap water only. If necessary, use a small brush to clean. Use caution while cleaning to prevent damage to Screen Filter.
- G** Examine the Copper Washer for wear or damage; replace if necessary. Carefully replace the Screen Filter into the Filter Cap. Screw the Filter Cap with Copper Washer into the Solenoid Valve Housing and tighten securely to prevent leaks.
- H** Turn on the water supply at the supply stop(s). Activate the Spray Head to purge any air from the system lines. Check for leaks and repair as necessary.
- I** Install Cover as instructed in Step 12.

Troubleshooting Guide

- 1. No water flows when sensor is activated**

Ensure that main power supply is turned "ON." Check receptacle, transformer, solenoid, leads and connections.

If Sensor LED does not blink:

 - A. Control module circuit board is faulty; replace.
 - B. Sensor is faulty; replace sensor module.

If Sensor LED blinks when user is sensed:

 - A. Supply Stop(s) may be closed; open Supply Stop(s).
 - B. Debris may be in Solenoid filter; remove, clean and reinstall.
- 2. Very low flow or slow dribble**
 - A. Supply Stop(s) may be closed; open Supply Stop(s).
 - B. Debris is in solenoid, won't close properly; remove operator and clean. Reassemble in the same manner.
 - C. Debris is in Solenoid filter; remove, clean and reinstall.
 - D. Debris is in spray head; remove, clean and reinstall.
- 3. Continues to run (even after power to faucet has been disconnected)**
 - A. Solenoid valve is installed backwards; install correctly.
 - B. Debris is in solenoid, won't close properly; remove operator and clean. Reassemble in the same manner.

Parts List

EW-72000 Double Station Head Assembly

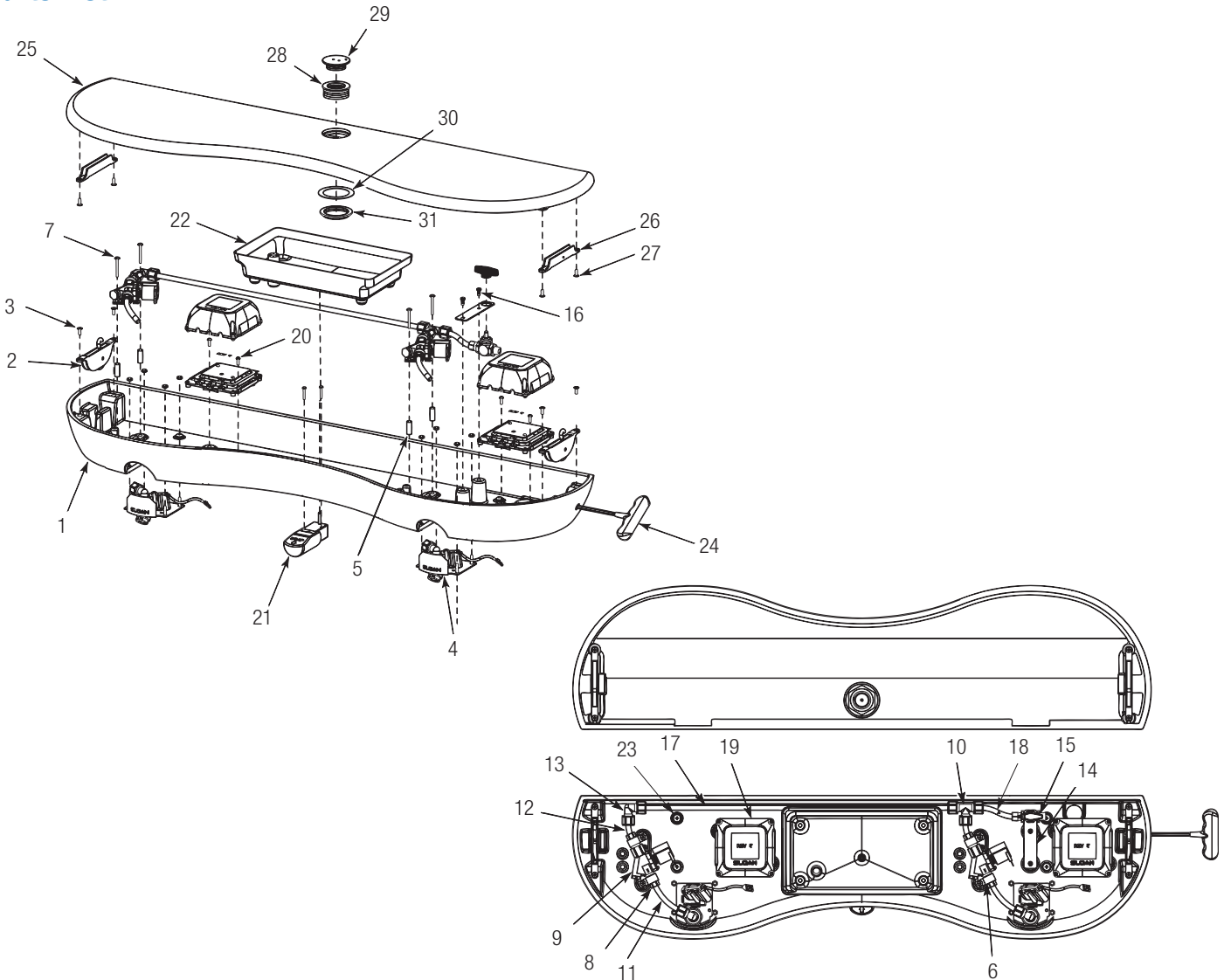

Item No.	Part No.	Description
1	EW-46	Electronics Enclosure 2 Station Machined
2	EW-41	Large Latch (2)
3	EW-27	Screw, Flat Head #10-24 x 1/2" Long (4)
4	EW-75-A	Sensor Plate Assembly (2)
5	EW-8	Spacer, #8 x 1" Long (4)
6	EW-13	Mounting Clamp for ETF-370-A Solenoid (4)
7	EW-9	Screw, Truss Head #8-32 x 1-1/2" Long (4)
8	ETF-61	Male Connector (4)
9	ETF-370-A	Solenoid Valve Assembly (2)
10	EW-19	Compression Tee Fitting 3/8" Tube
11	EW-89-00362	Tube, 3/8" x 3-5/8" Long (2)
12	EW-89-00188	Tube, 3/8" x 1-7/8" Long (2)
13	EW-18	Compression Elbow Fitting, 3/8" Tube
14	EW-5	Mounting Bracket for Shut-off Valve
15	EW-74	Panel Mount Ball Valve - 3/8" Compression Fitting
16	EW-36	Screw, Pan Head #8-32 x 7/16" Long (SEMS)(2)
17	EW-89-02525	Tube, 3/8" x 25-1/4" Long
18	EW-89-00388	Tube, 3/8" x 3-7/8" Long
19	ETF-450-A	Splash Proof Junction Box Assembly (2)
20	EW-28	Screw, Round Head #8-32 x 1/2" Long (4)
21 †	ESD-255-A	Manual Soap Pump Assembly

Item No.	Part No.	Description
22 †	ESD-245-A	Manual Soap Reservoir Assembly
23	EW-37	Screw, Truss Head 1/4-20 x 1-1/2" (4)
—	EW-26	Tube Support 3/8" (5) (Not Shown)
—	MIX-135-A	Thermostatic Mixing Valve (Below Deck) (Not shown)
—	EW-87	Flexible Supply Hose, 2 Station (Not Shown)
—	EW-82-A	Wiring Harness, 2 Station (Not Shown)
—	ETF-233	Transformer (Not shown)
—	ETF-731	Vandal Proof Key, Standard and Junior (Not shown)
24	EW-96	T-Handle Hex Wrench, 7/32"
25	EW-48-X	Cover, Electronics Enclosure, 2 Station Machined
26	EW-42	Large Encased Receiver (2)
27	EW-27	Screw, Flat Head #10-24 x 1/2" Long (4)
28 ‡	ESD-242	Sleeve for Fill Cap
29 ‡	ESD-241	Fill Cap for Soap Reservoir
30 ‡	EW-11	Gasket - Fill Cap Sleeve (Manual Soap Reservoir)
31 ‡	ESD-243	Jam Nut for Fill Cap Sleeve
— ‡	ESD-249	Fill Cap Spanner (Not Shown)

† Included on models with Soap Dispenser.

‡ Included on models with Fill Cap.

EW-72000 Double Station Cabinet and Basin Assemblies

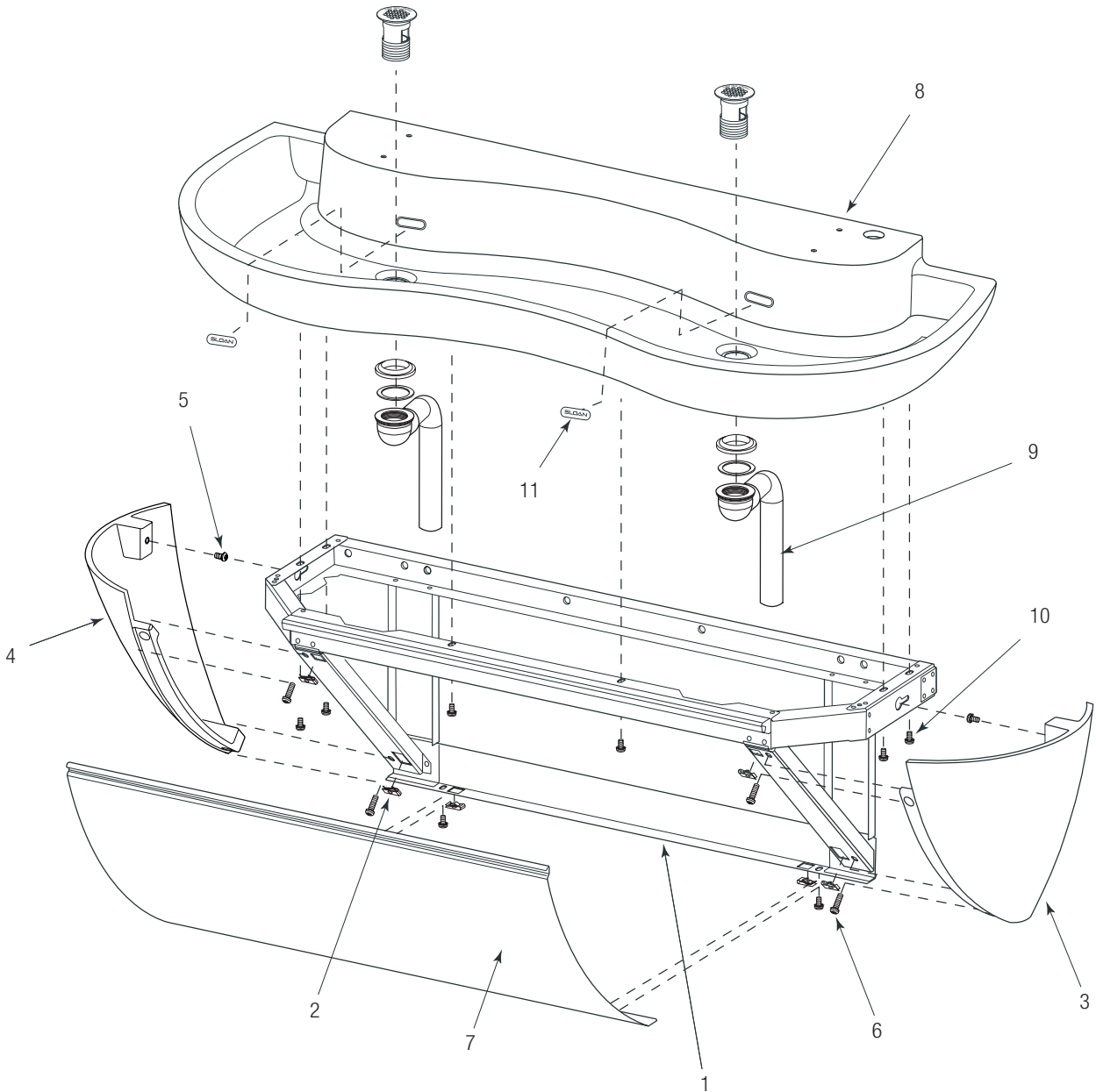

ItemPart No. No.	Description
1 EW-20-A	Cabinet Weldment, 2 Station
2 EW-99	U-Type Nut Standard 1/4-20 Thread (6)
3 EW-60	End Cap Right - Machined
4 EW-52	End Cap Left - Machined
5 EW-15	Screw, Pan Head 1/4-20 x 1/2" Long (SEMS) (4)
6 EW-16	Screw, Pan Head 1/4-20 x 1" Long (SEMS) (4)
7 EW-25	Front Panel, 2 Station

ItemPart No. No.	Description
8 EW-44	Basin 2-Station Machined
9 ETF-725-A	Grid Strainer Assembly (2)
10 EW-15	Screw, Pan Head 1/4-20 x 1/2" Long (SEMS) (6)
11 EW-61	Overflow Cover Plate (2)
— EW-98	Light Duty Buffing Pad (Not Shown)

EW-73000 Triple Station Head Assembly

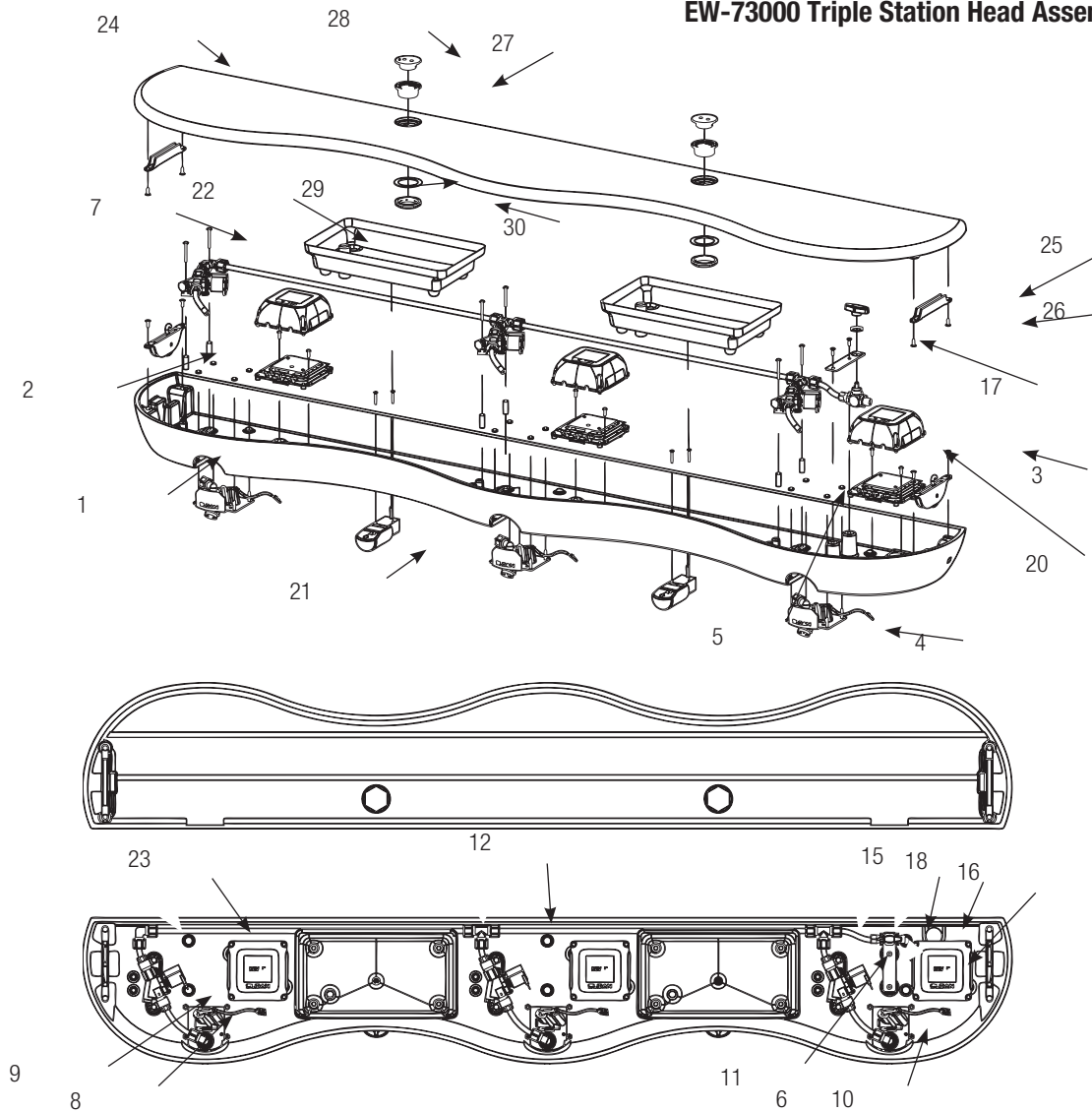

Item No.	Part No.	Description
1	EW-56	Electronics Enclosure, 3 Station Machined
2	EW-41	Large Latch (2)
3	EW-27	Screw, Flat Head #10-24 x 1/2" Long (4)
4	EW-75-A	Sensor Plate Assembly (3)
5	EW-8	Spacer #8 x 1" Long (6)
6	EW-13	Mounting Clamp ETF-370-A Solenoid (6)
7	EW-9	Screw, Truss Head #8-32 x 1-1/2" Long (6)
8	ETF-61	Male Connector (6)
9	ETF-370-A	Solenoid Valve Assembly (3)
10	EW-89-00362	Tube 3/8" x 3-5/8" Long (3)
11	EW-89-00188	Tube 3/8" x 1-7/8" Long (3)
12	EW-19	Compression Tee Fitting 3/8" Tube (2)
13	EW-18	Compression Elbow Fitting 3/8" Tube
14	EW-89-02525	Tube 3/8" x 25-1/4" Long (2)
15	EW-89-00388	Tube 3/8" x 3-7/8" Long (1)
16	EW-5	Mounting Bracket for Shut-off Valve
17	EW-36	Screw, Pan Hd #8-32 x 7/16" Long (SEMS) (2)
18	EW-74	Panel Mount Ball Valve - 3/8" Compression Fitting
19	ETF-450-A	Splash Proof Junction Box Assembly (3)
20	EW-28	Screw, Round Head #8-32 x 1/2" Long (6)
21 †	ESD-255-A	Manual Soap Pump Assembly (2)

Item No.	Part No.	Description
22 †	ESD-245-A	Soap Reservoir Assembly (2)
23	EW-37	Screw, Truss Head 1/4-20 x 1-1/2" Long (6) (Not Shown)
—	EW-26	Tube Support 3/8" (7) (Not Shown)
—	MIX-135-A	Thermostatic Mixing Valve (Below Deck) (Not Shown)
—	EW-92-A	Wiring Harness 3 Station (Not Shown)
—	ETF-233	Transformer (Not Shown)
—	ETF-731	Vandal Proof Key, Standard and Junior (Not Shown)
—	EW-97	Flexible Supply Hose, 3 Station (Not Shown)
—	EW-96	T-Handle Hex Wrench 7/32" (Not Shown)
24	EW-58-X	Cover, Electronics Enclosure, 3 Station Machined
25	EW-42	Large Encased Receiver (2)
26	EW-27	Screw, Flat Head #10-24 x 1/2" Long (4)
27 ‡	ESD-242	Sleeve for Fill Cap (2)
28 ‡	ESD-241	Fill Cap for Soap Reservoir (2)
29 ‡	EW-11	Gasket for Fill Cap Sleeve (2)
30 ‡	ESD-243	Jam Nut for Fill Cap Sleeve (2)
— ‡	ESD-249	Fill Cap Spanner (Not Shown)

† Included on models with Soap Dispenser.
‡ Included on models with Fill Cap.

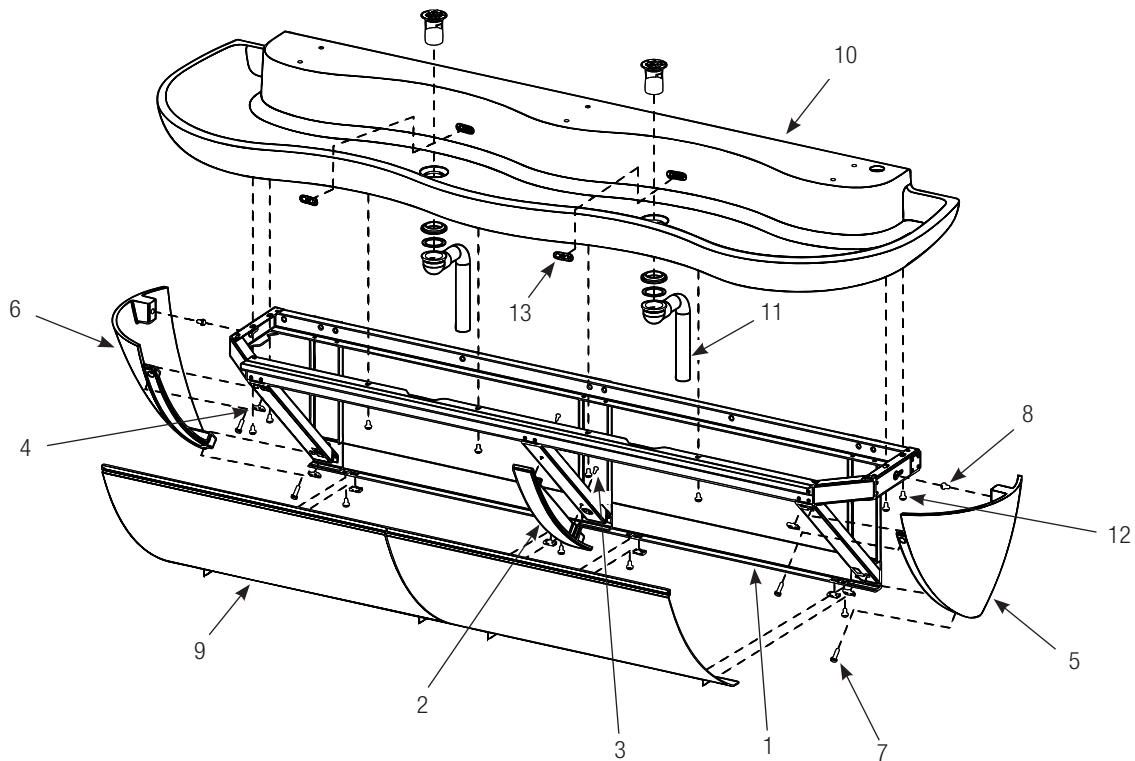

ItemPart No. No.	Description
1 EW-30-A	Cabinet Weldment, 3 Station
2 EW-50	Front Panel Support - Machined
3 EW-36	Screw, Pan Head #8-32 x 7/16" Long (SEMS) (2)
4 EW-99	U-type Nut, Standard 1/4-20 Thread (8)
5 EW-60	End Cap Right - Machined
6 EW-52	End Cap Left - Machined
7 EW-16	Screw, Pan Head 1/4-20 x 1" Long (SEMS) (4)

ItemPart No. No.	Description
8 EW-15	Screw, Pan Head 1/4-20 x 1/2" Long (SEMS) (2)
9 EW-35	Front Panel, 3 Station (2)
10 EW-54	Triple Station Lavatory Basin Assembly
11 ETF-725-A	Grid Strainer Assembly (2)
12 EW-15	Screw, Pan Head 1/4-20 x 1/2" Long (SEMS) (8)
13 EW-61	Overflow Cover Plate (2)
— EW-98	Light Duty Buffing Pad (Not Shown)

Operation

As the user's hands pass under the spray head and enter the beam's effective range, the beam is reflected back into the sensor receiver and activates the solenoid valve allowing water to flow from the Spray Head. Water will flow until the user's hands are removed from under the Spray Head or until the automatic time out limit setting is reached.



When assistance is required, please contact Sloan Valve Company Installation Engineering Department at:

1-888-SLOAN-14 (1-888-756-2614)

OR

1-847-233-2016

The information contained in this document is subject to change without notice.